

INTERNATIONAL JOURNAL OF ENGINEERING SCIENCES & MANAGEMENT

Study of various types of Topologies and Control techniques for PV FED Multilevel Inverter

Gaurav Singh¹ and Varsha Mehar²

¹M.Tech. Scholar, Department of Electrical Engineering, Bhabha College of Engineering, Bhopal (M.P.), India

²HOD, Department of Electrical Engineering, Bhabha College of Engineering, Bhopal (M.P.), India

Abstract

Inverters are a power electronic device which converts dc power into ac power at required voltage and frequency. Now a day's inverter demand is increased for renewable energy applications. Presence of renewable energy is highly unpredictable as it can be change with time. A conventional inverter topology is difficult to fulfill requirement of renewable energy system. Multilevel inverters are used for renewable energy application. Multilevel inverter topology has been developed for used in medium voltage and high power applications. It offers lower total harmonic distortion and switching losses. This paper presents a review on most important topologies and control techniques of multilevel inverter.

Keywords: Multilevel Inverter, Total Harmonic Distortion, Renewable energy sources.

Introduction

Multilevel inverter is introduced with an aim to reduce total harmonic distortion and switching losses [1]. This aim is to be obtaining by reaching output voltage in staircase waveform. This output waveform approximated sine wave with large number of steps in staircase waveform. Multilevel inverter systems composed by an array of power semiconductors and DC voltage sources. After appropriately connected and controlled, they generate output voltages with stepped waveforms. The output voltage waveform is synthesized from different DC levels supported by series connected batteries. When a number of levels increases, output waveform have more steps, which producing a fine stair case waveform and approach towards very closed to desired sine waveform [2].

Due to small output voltage step, multilevel inverters have lower harmonic components, high voltage capability, lower switching losses, high power quality and better electromagnetic compatibility. Multilevel inverters are easily interfaced with renewable energy sources; such as photovoltaic, wind and fuel cells for a high power application [3]. Multilevel inverter also used for renewable hybrid energy system, which consists of two or more energy sources.

Topology is basic requirement of multilevel inverter for its operation, power rating, efficiency and applications. The most commonly multilevel inverter topologies are Cascaded H-bridge multilevel inverter, Diode clamped multilevel inverter and Flying capacitor multilevel inverter. Hybrid multilevel topologies can also developed by combining of these topologies. Multilevel inverter control techniques based on fundamental and high switching frequency are Sinusoidal pulse width modulation, Space vector control, Space vector pulse width modulation and Selective harmonic elimination pulse width modulation [4].

Multilevel Inverter Topology

Cascaded H-Bridge Multilevel Inverter

A Cascade H-bridge multilevel inverter is based on connecting H-bridge inverters in series for getting a sinusoidal output voltage. The output voltage is the sum voltage, which is generated by each DC source [5]. The number of output voltage levels are $2n+1$, where n is the number of DC sources. The switching angles of this inverter chosen in this way, that the total harmonic distortion is minimum obtained [6]. This topology has following advantages; (a) It allows the scalable, modularized circuit layout and packing, due to same structure, (b) for getting same number of voltage level, number of components is less needed. The main disadvantage of this topology is need of separate DC sources for each H-bridge. Motor drives, active filters, electric vehicle drives and power factor compensators are the application area of this multilevel inverter. Structure of five level cascaded H-bridge multilevel inverter as shown in Fig. 1.

Diode Clamped Multilevel Inverter

Diode clamped multilevel inverter also known as neutral-point (NPC) multilevel inverter. Uses of diode as clamping device is the main concept of diode clamped multilevel inverter. Due to limited amount of voltage transfers by diode, stress reducing on other electrical devices. The maximum output voltage is the half of input DC voltage. By increasing switches, diodes & capacitors in Diode clamped multilevel inverter, the output voltage also increased [7]. The switching angles of this inverter chosen in this way, that the total harmonic distortion is minimum obtained. This topology has following advantages; (a) Filters are not needed for reducing harmonics, (b) Efficiency is high, (c) Method of control is simple. The main disadvantage of this topology is

control of real power flow in individual inverter is difficult. Static VAR compensation and variable speed motor drives are the application area of this multilevel inverter. Structure of five level diode clamped multilevel inverter as shown in Fig. 2. The five level diode clamped multilevel inverter uses switches, diodes and capacitor.

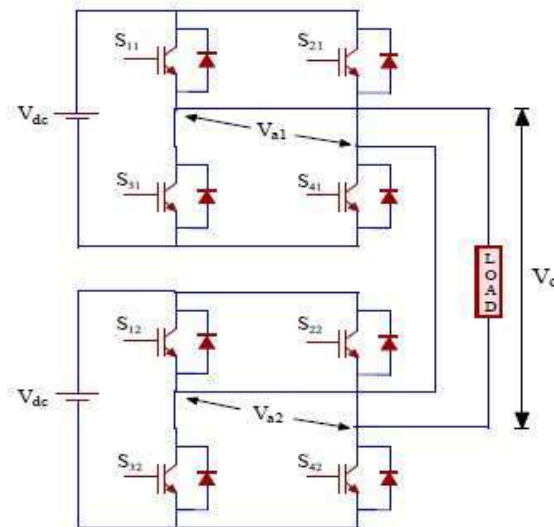

Fig. 1 Five Level cascaded H-bridge Multilevel Inverter

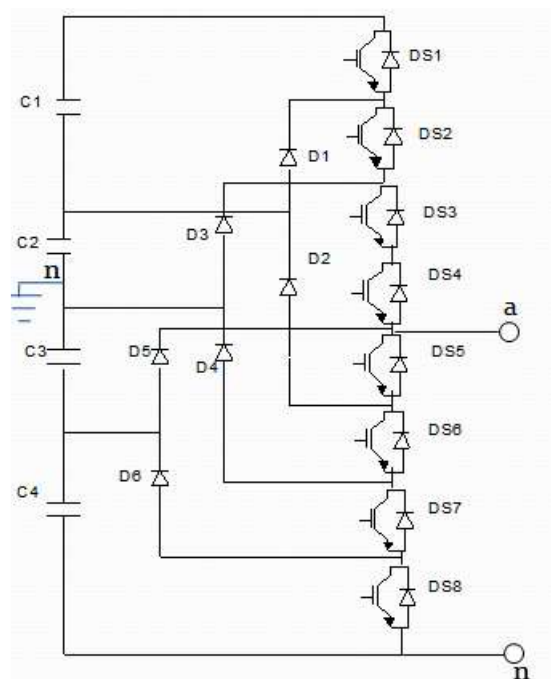

Fig. 2 Five Level Diode Clamped Multilevel Inverter

Flying Capacitor Multilevel Inverter

The structure of flying capacitor multilevel inverter is same as diode clamped multilevel inverter except using of capacitor instead of clamping diodes. Capacitors are connected in series. They limited amount of voltage to electrical devices by divide the input DC voltage. The switching angles of this inverter chosen in this way, that the total harmonic distortion is minimum obtained [8]. This topology has following advantages; (a) Control both active and reactive power flow, (b) Efficiency is high, (c) It gives balance different voltage levels by proper switching combination. The main disadvantage of this topology is switching losses occurs due to high switching frequency. Sinusoidal current rectifiers, static VAR generation and induction motor control using DTC circuit are the application area of this multilevel inverter. Structure of five level flying capacitor multilevel inverter as shown in Fig. 3. The five level flying capacitor multilevel inverter uses switches and capacitors.

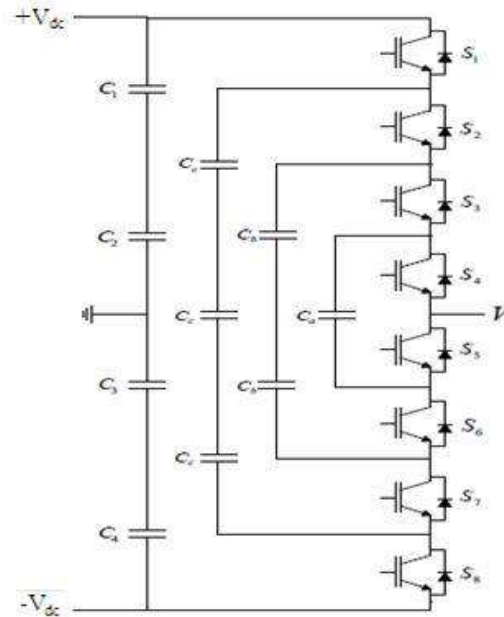

Fig. 3 Five Level Flying Capacitor Multilevel Inverter

Multilevel Inverter Control Techniques

Sinusoidal Pulse Width Modulation

The control principle of sinusoidal pulse width modulation is to use several triangular carrier signals keeping only one modulating sinusoidal signal. Modulating signal at every instant is compared with each carrier signal. The switch “ON” in each comparison switches, if modulating signal is greater than triangular carrier assigned to that switch [9]. If f_c is frequency of carriers and f_m is frequency of modulating signal, then main parameters of modulation process are frequency ratio is defined as $k = f_c/f_m$. Modulation index (MI) is defined as the ratio of amplitude of modulating signal to amplitude of triangular carrier.

$$MI = A_m / A_c \quad (1)$$

Equation (1) is given modulation index. Where, A_m is amplitude of modulating signal and A_c is amplitude of triangular carrier. Amplitude of the applied output voltage is controlled by modulation index [10].

Space Vector Control

Space vector control is used for generating sine waveform, which provides voltage to motor with lower total harmonic distortion (THD). Switching control for cascade H-bridge inverters are based on space vector theory. Space vector control is popular for generates a voltage vector with very low harmonic distortion and switching losses. It used for better utilization of the DC bus compared to conventional PWM modulation. In space vector control, generate the switching signals directly by using the space vector of reference voltage, without convert space vector to three phase values at first. They also generate a voltage vector across load of minimum error with respect to sinusoidal reference [11].

Space Vector Pulse Width Modulation

Space vector pulse width modulation is more simple technique with respect to space vector control for generating a fundamental sine waveform, which provides a higher voltage to motor with lower total harmonic distortion (THD). Space vector pulse width modulation executed efficiently in few second. They achieve same results as compared with other PWM methods. In space vector pulse width modulation, reference signal is sampled regularly. After each signal, non- zero active switching vectors adjacent to reference vector and one or more of the zero switching vectors are selected for appropriate fraction of the sampling period in order to synthesize reference signal as the average of used vectors [12].

Selective Harmonic Elimination Pulse Width Modulation

Selective harmonic elimination pulse width modulation is low switching frequency PWM method developed for cascaded multilevel inverters with optimized DC voltage levels. Initial value for SHE-PWM equations according to reference modulation index (MI) and initial phase angle of fundamental output voltage investigated according. In SHE-PWM, regulate a voltage across the flying capacitors at their reference voltage levels by swapping switching patterns of the switches based on the divergence of output current, divergence of flying capacitor voltage and divergence of fundamental line to neutral voltage. SHE-PWM provides a narrow range of modulation index, which is main disadvantage of SHE-PWM [13].

Conclusions

In this paper various types of multilevel inverter topologies and control techniques have been reviewed, which helps researchers to use proper techniques to control multilevel inverters for power generated by renewable energy sources. Cascaded H-bridge requires minimum number of components as compare to another topology and control circuit also becomes less complex. It produces an increased stepped output with less number of semiconductor switches [14].

References

1. Apurva Tomar, Dr. Shailja Shukla , “ Reduction in Total Harmonic Distortion Using Multilevel Inverters ” International Journal of Electrical and Electronics Research, Vol. 3, Issue 1, pp: 80-84, Month: January - March 2015.
2. J. Rodriguez, J.S. Lai and F.Z. Peng, “Multilevel inverters: survey of topologies, controls, and applications,” IEEE Trans Ind. Appl., Vol. 49-4, pp: 724–738, Aug. 2002.
3. Sachin Jain and Vivek Agarwal, “An Integrated Hybrid Power Supply for Distributed Generation Applications Fed by Nonconventional Energy Sources” IEEE transactions on energy conversion, Volume: 23, Issue: 2, pp: 622-631, 2008.
4. Avinash verma, Ruchi shivhare, Sanjeev gupta “Total Harmonics Distortion Investigation in Multilevel Inverters ”, American Journal of Engineering Research (AJER) , Volume-02, Issue-07, pp:159-166 , 2013.
5. Lalit Dutta, Raj Kiran B, V Siva Brahmaiah Rama , “ Cascaded Multilevel Inverters for Photovoltaic Power System Applications ” International Journal of Advanced Research in Electrical, Electronics and Instrumentation Engineering , Vol. 4, Issue 7, July 2015.
6. Jigar Patel, Raj Kapadia, Darshan Patel, “Simulation And Analysis Of Cascaded H-Bridge Multilevel Inverter Using Single DC Source”, International Journal of Emerging Technology and Advanced Engineering, Volume 3, Issue 4, April 2013.
7. S.Shalini, “Voltage Balancing in Diode Clamped Multilevel Inverter Using Sinusoidal PWM ”, International Journal of Engineering Trends and Technology (IJETT), Vol. 6, No. 2, Dec 2013.
8. Sayli Khadse, Rohini Mendole and Amarjeet Pandey, “ A 5-Level Single Phase Flying Capacitor Multilevel Inverter ”, International Research Journal of Engineering and Technology (IRJET), Vol. 4, Issue 2, Feb. 2017
9. K. Gopala Krishnan, M. Sundar Raj and T. Saravanan, “ Harmonic Evaluation of Multicarrier PWM Techniques for Cascaded Multilevel Inverter ”, Middle-East Journal of Scientific Research ,Vol. 20 , No. 7, pp: 819-824, 2014 .
10. Pablo Lezana, Jose Rodriguez, and Diego A. Oyarzun, “Cascaded Multilevel Inverter with Regeneration Capability and Reduced Number of Switches”, IEEE Trans. On Industrial Electronics, Vol. 55, No. 3, pp.1059-1066, March 2008.
11. Jose Rodriguez, Luis Moran, Pablo Correa, and Cesar Silva, “A Vector Control Technique for Medium-Voltage Multilevel Inverters”, IEEE Trans. On Industrial Electronics, Vol. 49, No. 4, pp. 882-888, Aug.2002.
12. Anish Gopinath, Aneesh Mohamed A. S., and M. R. Baiju, “Fractal Based Space Vector PWM for Multilevel Inverters—A Novel Approach”, IEEE Trans. On Industrial Electronics, Vol. 56, No. 4, pp. 1230-1237, April 2009.
13. Vladimir Blasko, “A Novel Method for Selective Harmonic Elimination in Power Electronic Equipment”, IEEE Trans. On Power Electronics, Vol. 22, No. 1, pp. 223-228, Jan. 2007.
14. Anjali Sudarsanan, Roopa R and Sanjana S, “Comparison of Conventional& New Multilevel Inverter Topology”, International Journal of Scientific & Engineering Research, Vol. 6, Issue 2, Feb. 2015